

# ARROCase: Early-Stage Glottic Cancer

Charles Vu, MD (PGY-4)

Faculty Advisor: Daniel Krauss, MD

Beaumont Health (Royal Oak, MI)

March 2018

# Case

- 72yo male current smoker (60 pack-year smoking history) presents with hoarseness x 1 month, no other symptoms
- Referred to ENT
  - Indirect mirror laryngoscopy shows 5-6mm nodule in anterior right true vocal cord
  - Both vocal cords fully mobile
- EUA with biopsy shows moderately differentiated squamous cell carcinoma
- CT neck/chest unremarkable (no lymphadenopathy)
- Final Stage: T1aN0M0 glottic carcinoma

# Treatment Options

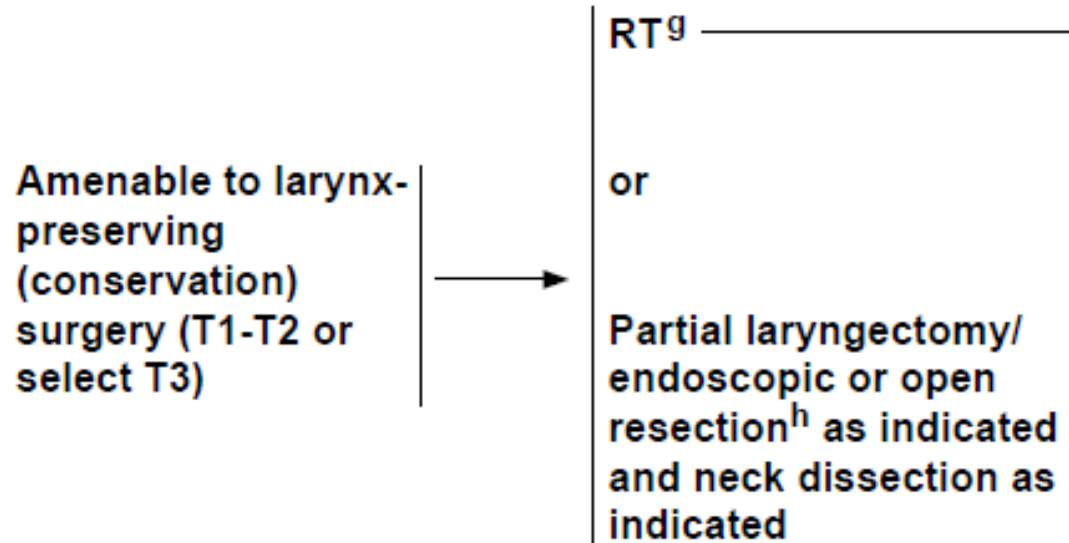

NCCN Guidelines, Head and Neck Ver 2.2017

# Surgery vs. RT

- Laser microsurgery and RT have similar oncologic and voice outcomes
- Partial laryngectomy has comparable outcomes to RT and laser microsurgery but inferior voice outcomes

Rosier Radiother Oncol. 1998 Aug;48(2):175-83.

# RT alone outcomes: University of Florida

- 585 patients with T1-T2N0 glottic cancer treated between 1964-2006 with RT alone
- Median follow-up 12 years
- LC outcomes: T1a: 94%, T1b: 93%, T2a: 80%, T2b: 70%

Chera Int J Radiat Oncol Biol Phys. 2010 Oct 1;78(2):461-6.

# Hypofractionated RT: Japanese RCT

- 180 patients with T1N0 glottic cancer randomized to 2Gy fractions (60-66Gy) vs. 2.25Gy fractions (56.25-63Gy)
- Hypofractionated RT had superior local control (92% vs. 77%,  $p = 0.004$ )
- No difference in cause-specific survival or toxicity

Yamazaki Int J Radiat Oncol Biol Phys. 2006 Jan 1;64(1):77-82

# Hyperfractionated RT for T2N0 Glottic Cancer (RTOG 9512)

- 250 patients with T2N0 glottic cancer randomized to hyperfractionated RT (79.2Gy in 66 fractions BID) versus standard fractionation RT (70Gy in 35 fractions QD)
- 5yr LC 78% in HFX arm vs. 70% in SFX arm ( $p = 0.14$ )
- Hyperfractionated associated with higher rates of acute skin, mucosal, and laryngeal toxicity, but similar G3-4 late toxicity

Trotti Int J Radiat Oncol Biol Phys. 2014 Aug 1;89(5):958-63.

# Impact of Smoking and Treatment Complications

- Van der Voet et al. studied 352 T1N0 glottic patients treated from 1965-1992
- Patients who continued smoking had significantly higher rate of complications at 10 years (28% vs. 13%)

Van der Voet et al. Int J Radiat Oncol Biol Phys. 1998  
Sep 1;42(2):247-55.



# Field Design

- Opposed lateral field arrangement with anterior wedged pair
- Classically 5x5cm box, but can also use 6x6cm
  - Centered on true vocal cord
  - Top of thyroid notch to bottom of cricoid cartilage
  - Vertebral bodies posteriorly, flash at least 1cm anteriorly
- Adjust field size to patient anatomy to cover larynx

# Field Design: Wedges

- Wedges should have the heel pointed anteriorly
- Some institutions adjust wedge angle based on location of tumor
  - Underwedge to give more dose to anterior larynx
  - Overwedge to give more dose to posterior larynx
- May be necessary to add bolus to ensure anterior commissure coverage
- Broad-shouldered men may require couch kick so that fields clear shoulders

# Back to the patient

- T1aN0M0 glottic cancer
- Recommended hypofractionated RT (6300cGy in 225cGy fractions) based on Japanese RCT

# Our Patient: Opposed Lateral Fields

- 6x6cm opposed lateral fields with wedged pair (heel pointed anteriorly)

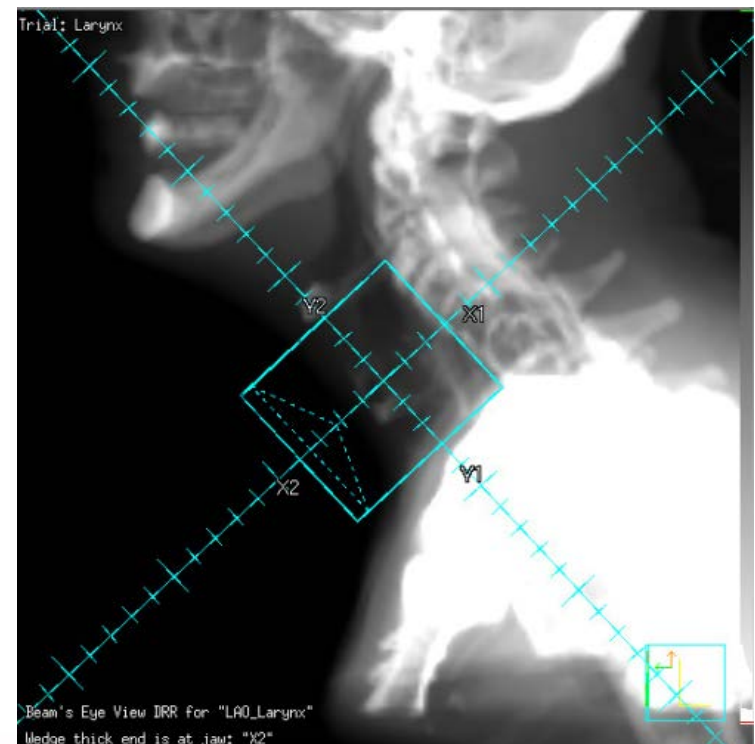
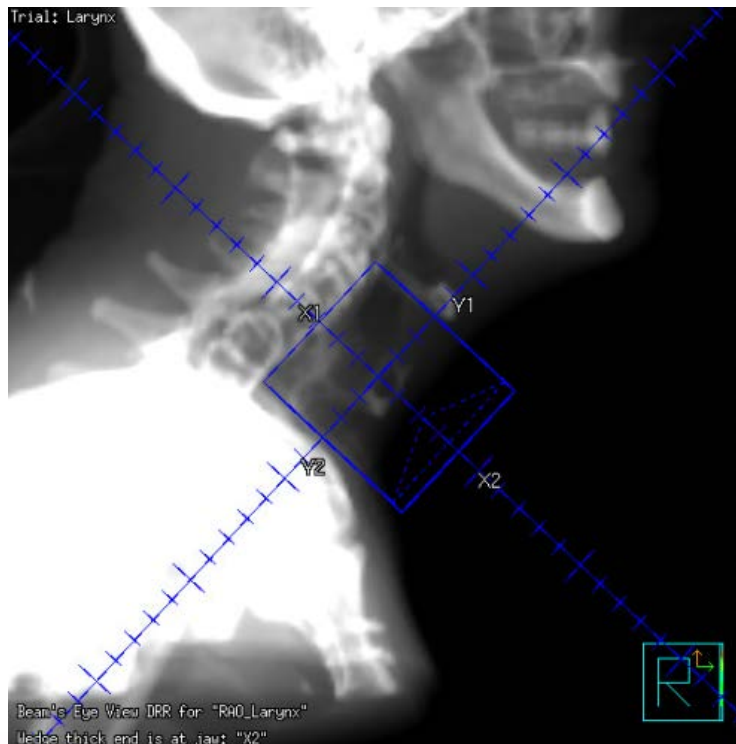

# Our Patient: Treatment Plan

- Verify adequate coverage of larynx
- Note the "underwedging" to give additional dose to anterior vocal cords (lesion location)

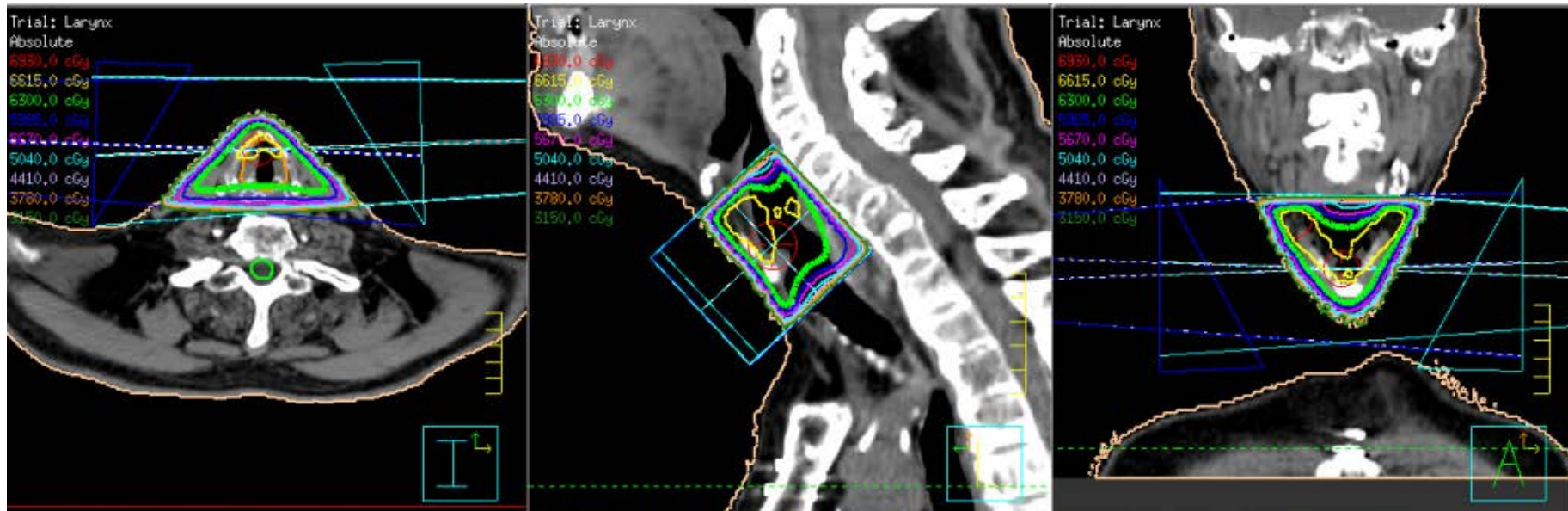

# Summary

- For T1N0 glottic lesions, definitive RT and laser microsurgery have similar oncologic and voice outcomes
- RT alone given using opposed lateral fields with wedge pair (heel pointed anteriorly)
- Strongly consider hypofractionated RT for early-stage glottic cancer because of superior LC in Japanese RCT

# References

1. Chapter 35: Larynx and Hypopharynx Cancer. Gunderson and Tepper, 4<sup>th</sup> edition, 2015.
2. NCCN Guidelines, Head and Neck Ver 2.2017
3. Rosier Radiother Oncol. 1998 Aug;48(2):175-83.
4. Van der Voet et al. Int J Radiat Oncol Biol Phys. 1998 Sep 1;42(2):247-55.
5. Chera Int J Radiat Oncol Biol Phys. 2010 Oct 1;78(2):461-6.
6. Yamazaki Int J Radiat Oncol Biol Phys. 2006 Jan 1;64(1):77-82
7. Trotti Int J Radiat Oncol Biol Phys. 2014 Aug 1;89(5):958-63.